







■ Features:

- Constant voltage output
- Protections: Short circuit / Over load
- Designed for indoor signage, decoration or lighting applications
- Unique aluminum chimney heat sink, best heat dispatching performance
- High output power up to 1000W
- 100% full load burn-in test

■ Specification:

SELV    

OUTPUT	DC Output	12V	24V	5V
	Output Current	83.3A	42A	160A
	Voltage Tolerance	5%		
	Rated Power	1000W Max.	1000W Max.	800W Max.
	Ripple Noise	200mV P-P		
	Setup Rise Time	1000mS/220V		
INPUT	Input Voltage	220V 15%		
	Frequency Range	47 ~ 63Hz		
	Efficiency	86%	88%	78%
	AC Current @ 220VAC	8.1A Max.	8A Max.	7.2A Max.
	AC inrush current(max.)	92A@230VAC		
PROTECTION	Over Load	105%-120% rated power , Protection Type:auto-recovery ,after fault condition is removed		
	Short Circuit	Protection Type:recovery automatically after fault condition is removed		
ENVIRONMENT	Operating Temperature	-25°C ~ +40°C		
	Operating Humidity	5% ~ 95%		
	Storage Temperature	-35°C ~ +65°C		
SAFETY & EMC	EMC	EN 55015 : 2006+A2 : 2009 ; EN 61547 : 2009 ; EN 61000-3-2 : 2006+A2 : 2009 ; EN 61000-3-3 : 2008		
	Withstand Voltage	I/P-FG:1.5KV AC I/P-O/P:3.0KV AC		
OTHERS	Dimension(mm)	293 x 189X90		
	Packing Dimension(mm)	500x 310 x205		
	Packing Weight(Kg)	5PCS/15		

■ Dimension:

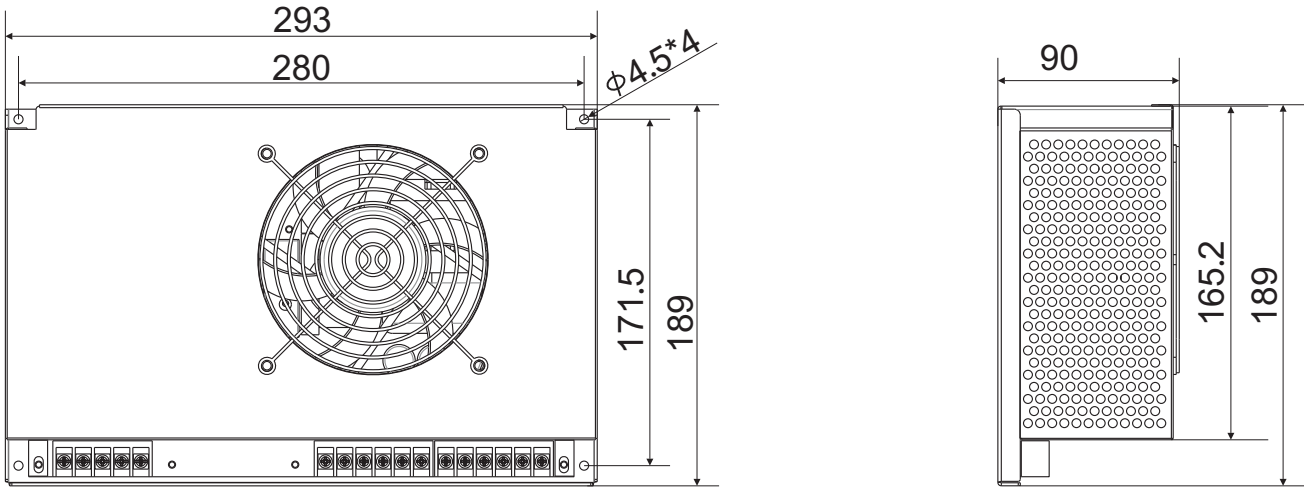

■ Wiring Diagram:

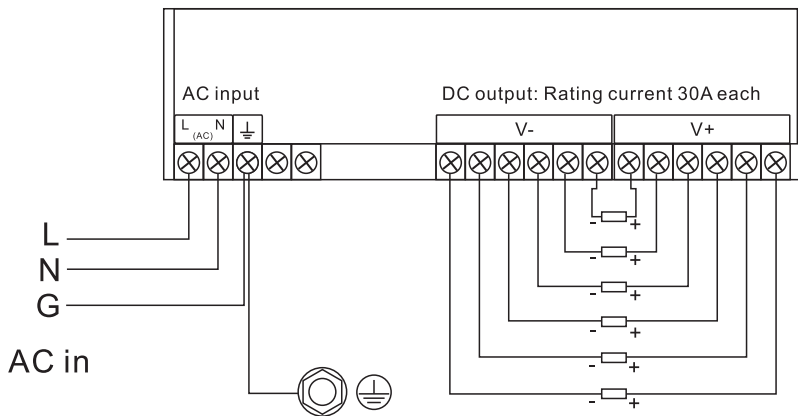

■ Derating Curve:

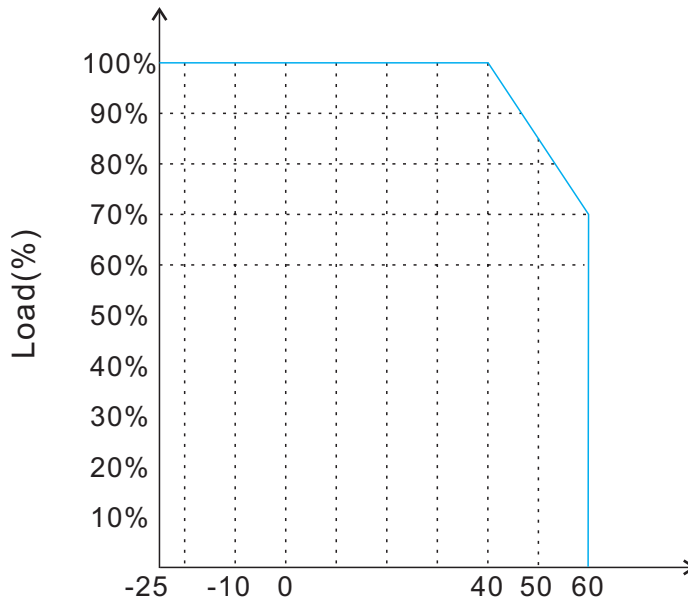

*NOTE: Start-up possible for 220VAC

■ Static Characteristic Curve:

